

LEGENDA

a	Calibratore aria principale	i	Iniettore pompa	a	Correction jet	i	Pump injector
E	Econostat	L	Leva comando pompa	E	Econostat	L	Pump lever
F	Galleggiante	M	Membrana pompa	F	Float	M	Pump membrane
g	Getto minimo	P	Sede ago	g	Pilot jet	P	Needle valve
Gg	Getto principale	V	Farfalla	Gg	Main jet	V	Butterfly
Gst	Getto starter	W	Vite regolazione minimo	Gst	Starter petrol jet	W	Volume control screw
K	Diffusore	X	Diffusore centrale	K	Choke tube	X	Central diffuser

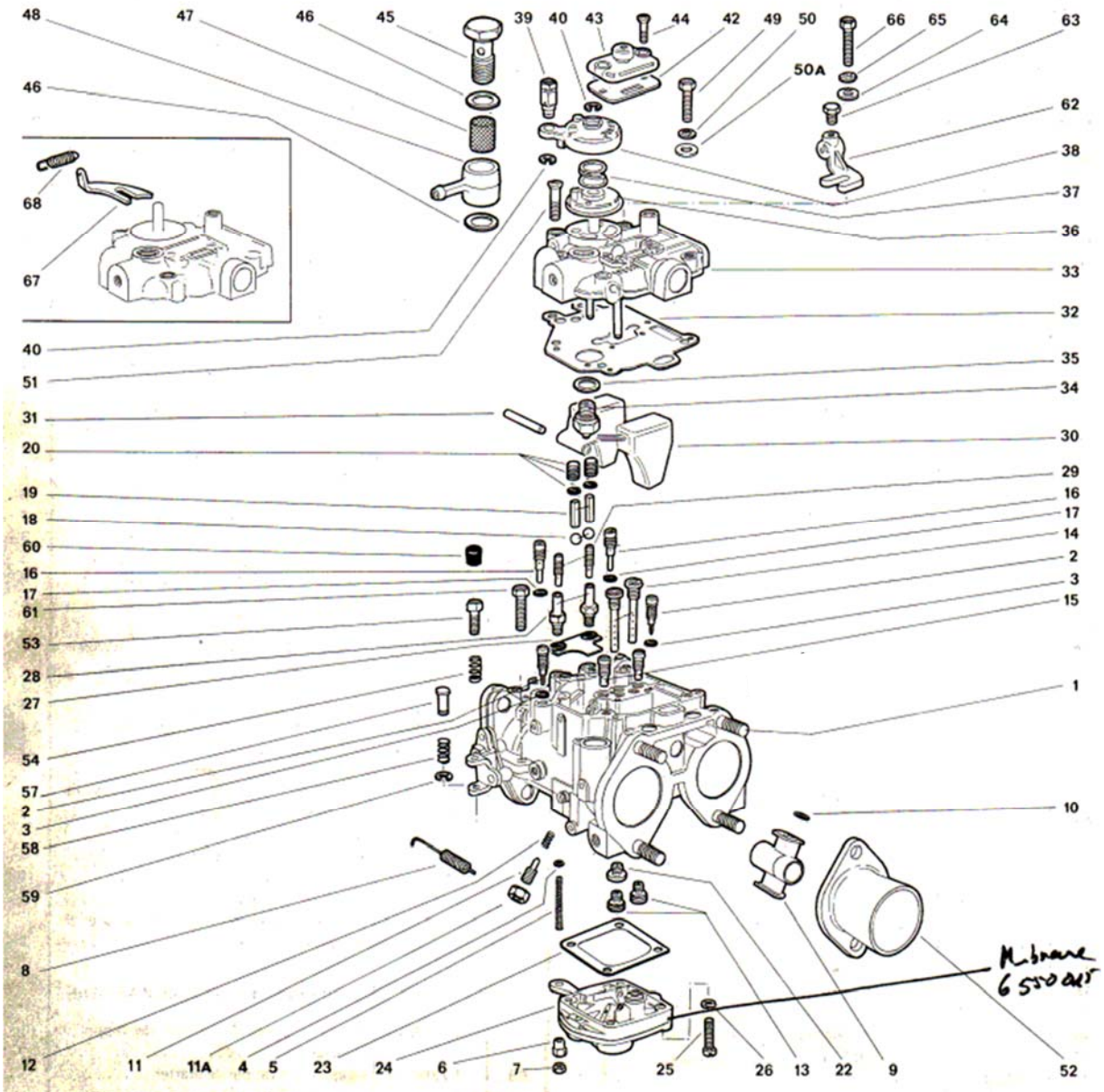

# CARBURATORE SOLEX

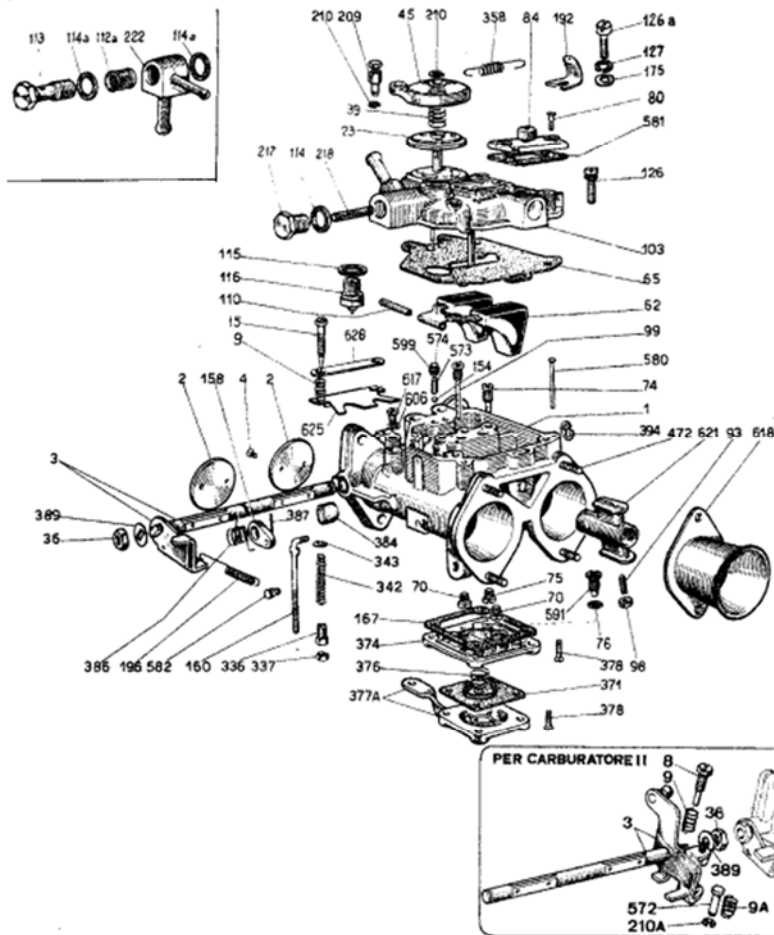

## 35 PHH-21 LANCIA fulvia berlina ed. 72

cod. Solex 6900572 ant.  
6900573 post.  
cat. Lancia 2293332 ant.  
2293333 post.

## 35 PHH-23 LANCIA fulvia coupé 1,3 S ed. 72

cod. Solex 6900574 ant.  
6900575 post.  
cat. Lancia 2293336 ant.  
2293337 post.

### REGOLAZIONE - SETTING

Diffusore  
Getto principale  
Calibratore aria principale  
Getto minimo  
Sede ago  
Galleggiante  
Getto starter  
Iniettore pompa

Choke tube  
Main jet  
Correction jet  
Pilot jet  
Needle valve  
Float  
Petrol jet  
Injector tube

K  
Gg  
a  
g  
P  
F  
Gst  
i

Cod. 6.900.572	Cod. 6.900.574	Cod. 6.900.573	Cod. 6.900.575
	29		31
	120		120
	190		180
	47		47
	1,1		1,1
	9 gr.		9 gr.
	90		90
	cal.40		cal.40